

Machining Division | *Exact*

Responsive Engineering Group

Engineering expertise you can rely on

Facility

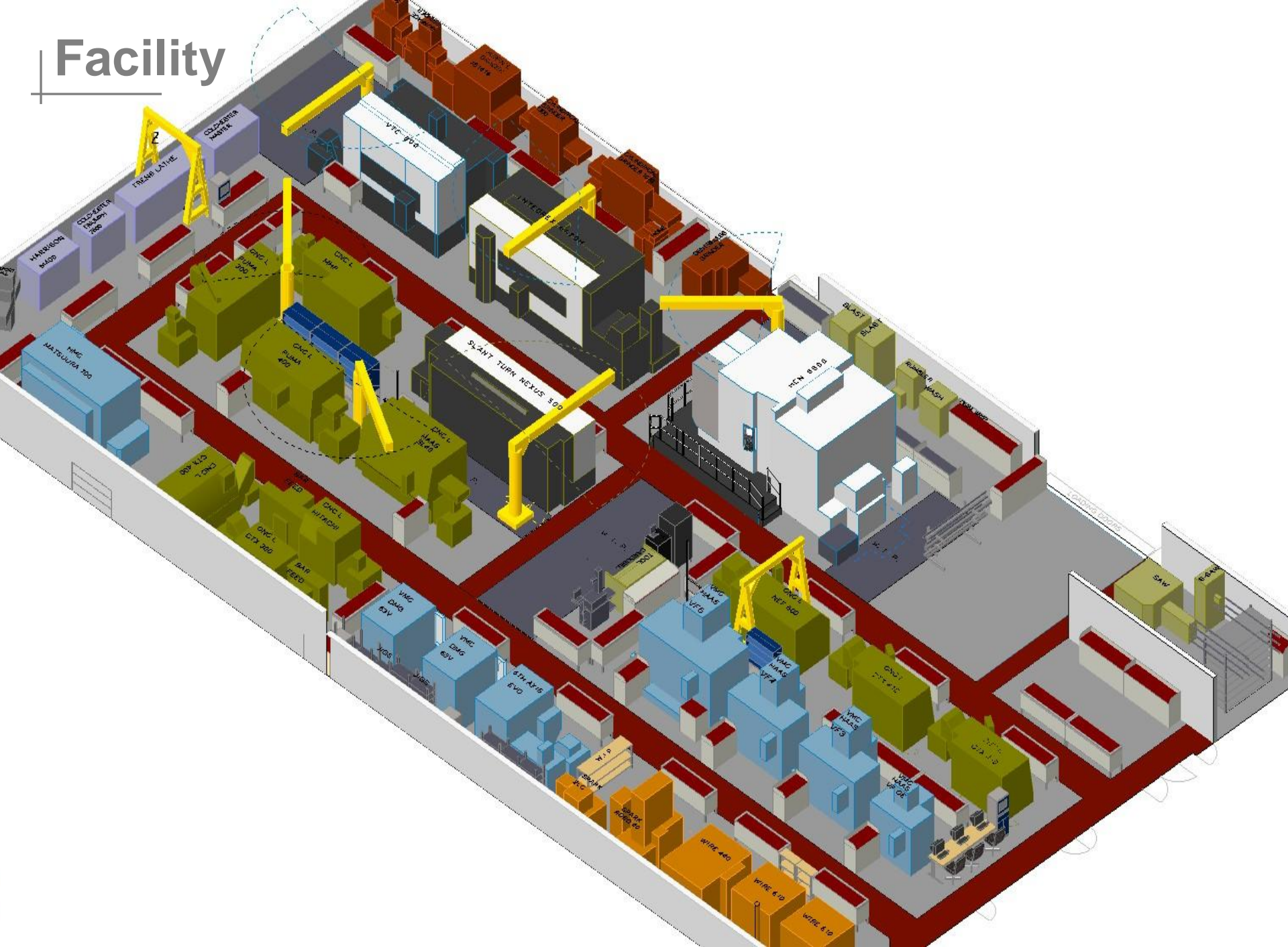

Facility



Resources

□ CNC Turning

- 12 CNC Lathes (up to 910mm dia & including Mazak Integrex)

□ CNC Milling

- 10 Vertical & Horizontal Machining Centres
- 5 Axis Machining
- Ultra High Accuracy
- Single & Twin Pallets
- Integrated Tool Measurement
- Renishaw Probing

□ CNC EDM

- 6 Wire Erosion & Solid Sink Machines

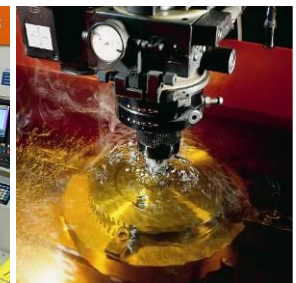

Resources

❑ Conventional Machining

- ❑ Milling (vertical, horizontal & universal)
- ❑ Turning
- ❑ Grinding (Surface, Cylindrical, Centerless)

❑ Support Processes

- ❑ Honing
- ❑ Sawing
- ❑ Grit & Bead blasting
- ❑ Deburring & Cleaning
- ❑ etc.

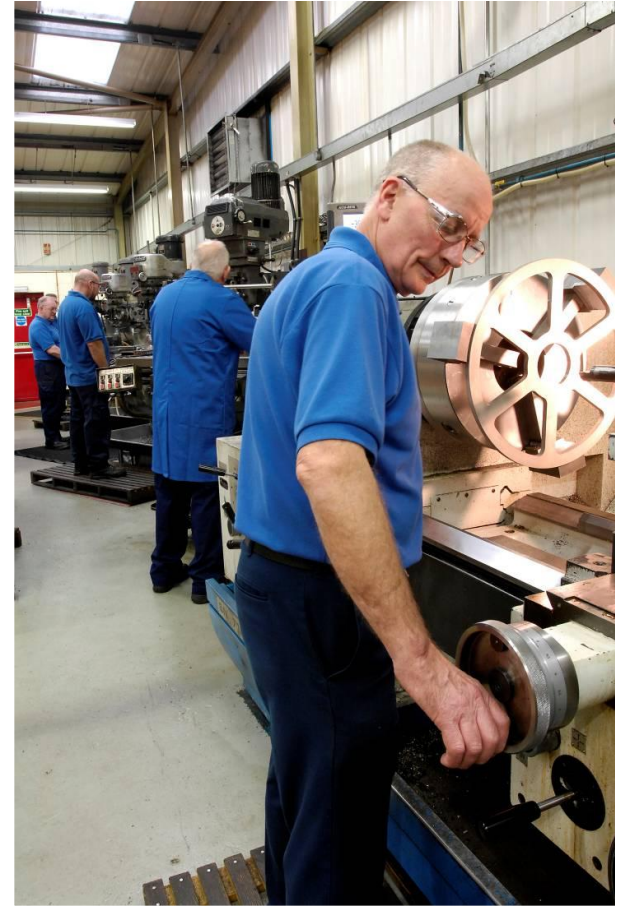

Key Resources



Mazak Integrex e420 HS-2

670mm dia x 3,060mm Travel

5Axis Turn/Mill

120 tools

380mm dia Chuck

117mm Thro' Spindle

4,000 rpm Turning (30kW)

12,000 rpm Milling (22kW)



Key Resources



Mazak Slant Turn 550M

910mm dia x 3,300mm Travel

1,040mm dia Max'm swing

Mill & Drill Turret (7.5kW)

610mm dia Chuck (165mm thro' bore)

185mm Thro' Spindle

4,000 rpm Turning (45kW)

4 tonne Max work piece

Heavy Duty

High Performance Turning Centre

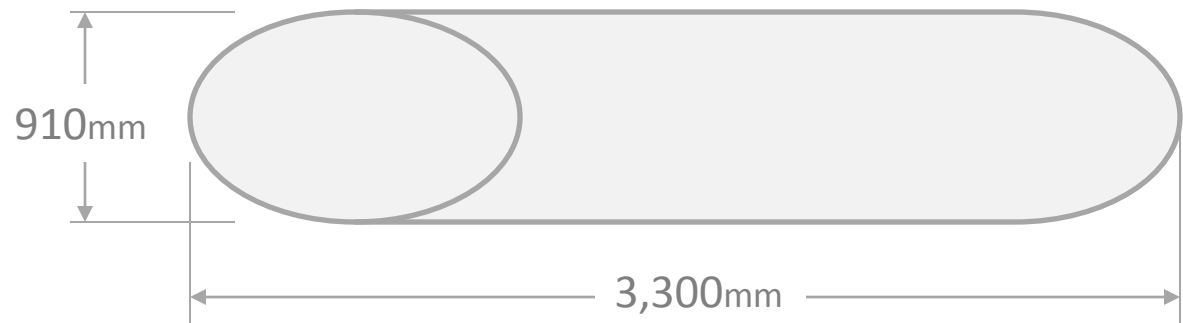

Key Resources



Mazak VTC 800/30SR

3,000mm x 800mm Travel

3,500mm x 820mm Table

2.5 tonne table load

5 Axis

18,000 rpm (26kW)

Probe Measurement System

80 tools

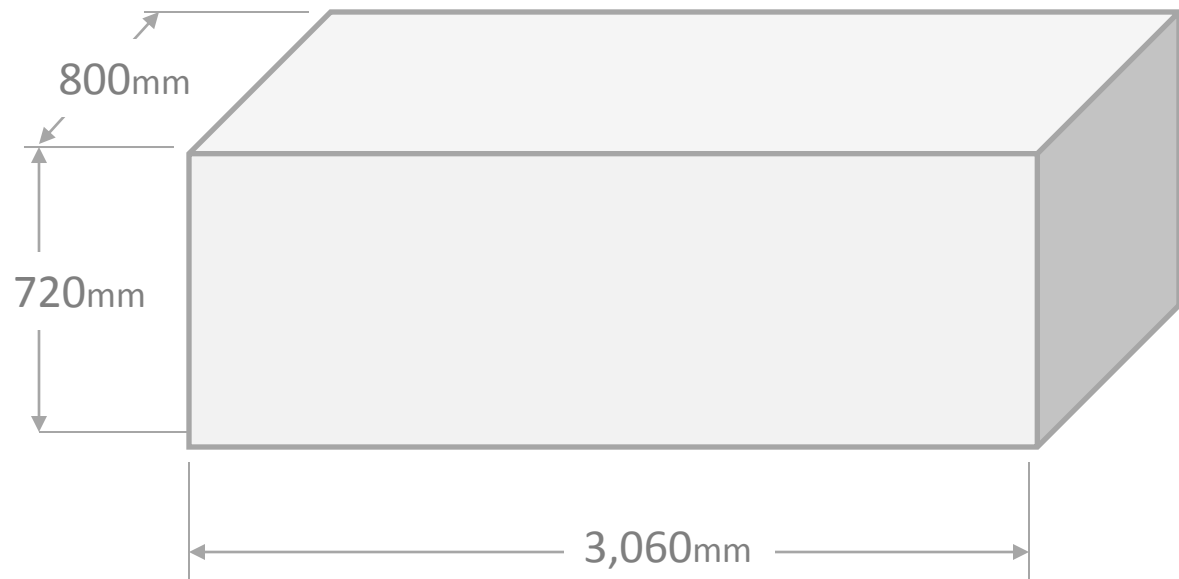



Key Resources

Ultra High Accuracy

Position & Repeat to 7 microns!

(0.007mm)

(0.000275")

The only one of its kind in the UK

Mazak HCN μ8800-2

X 1,400mm Y 1,200mm Z 1,325mm Travel

Full B Axis rotary machining

2.5 tonne table load

10,000 rpm (37kW)

Probe Measurement System

120 tools

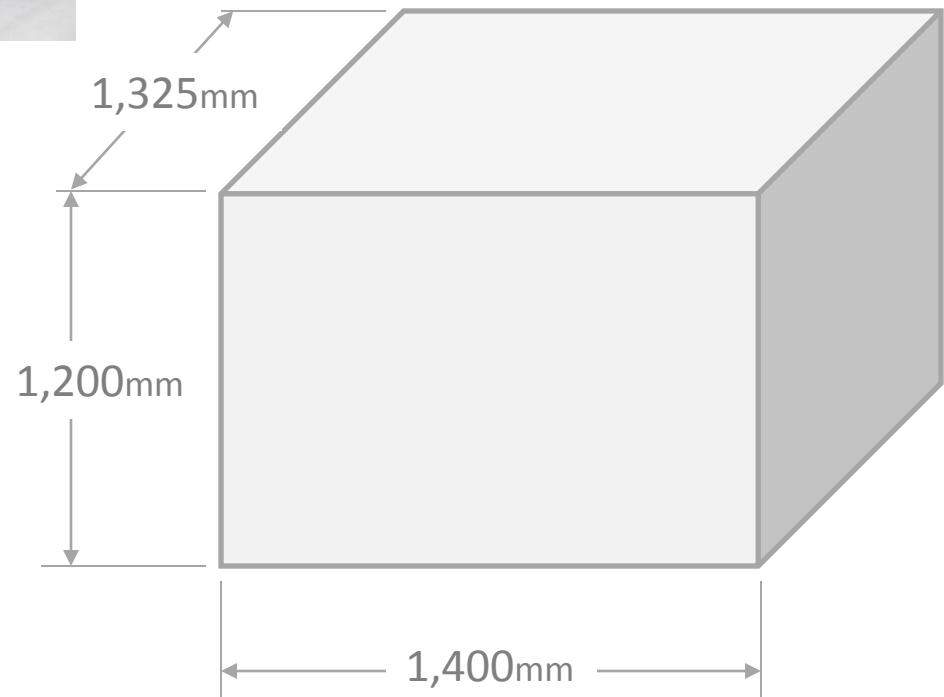

Product Examples

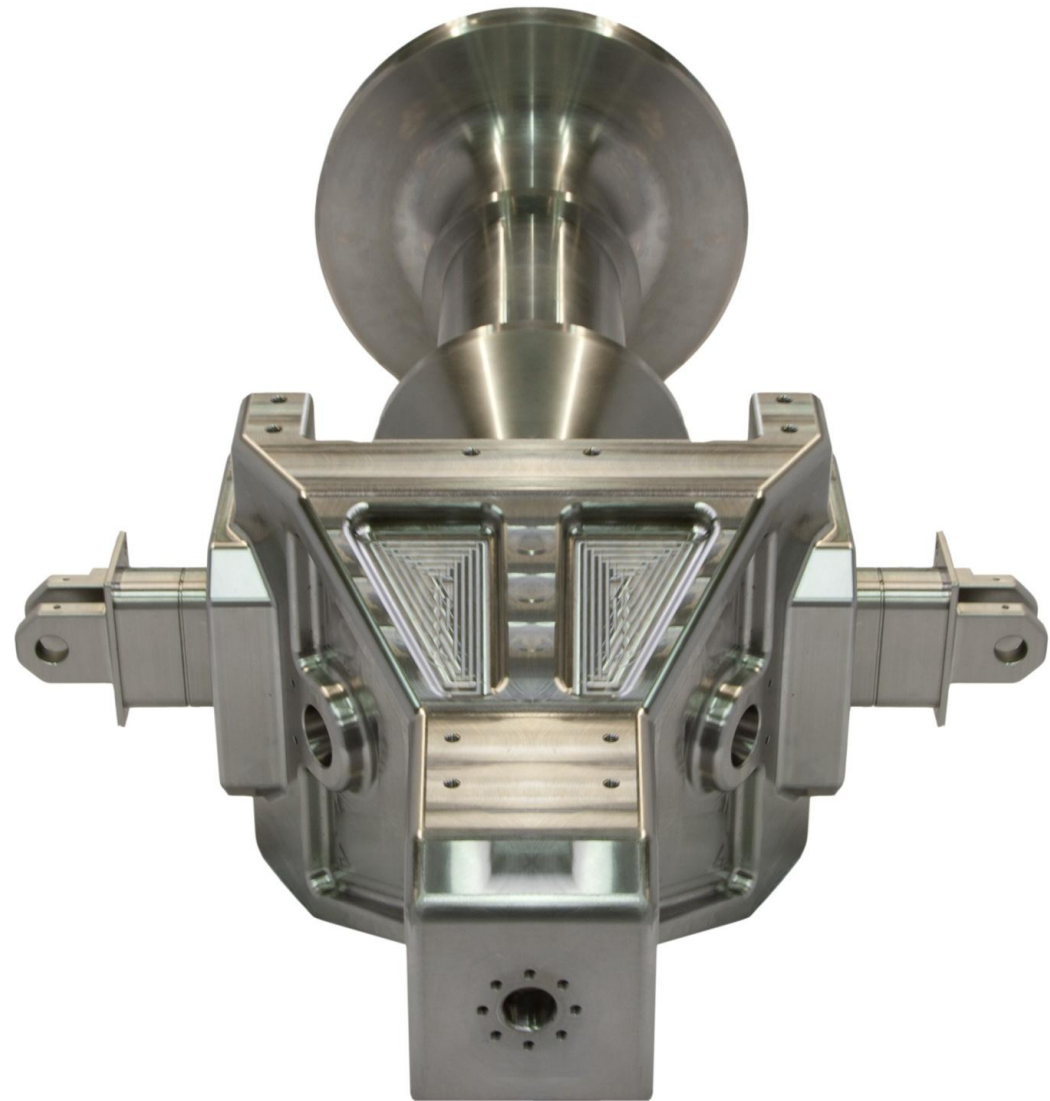

The Group

**Exact is a Division of the Responsive Engineering Group
whose broader offering includes:**

Exact

- ❑ CNC Machining
- ❑ CNC EDM
- ❑ Conventional Machining

Pressex

- ❑ Pressing & Forming
- ❑ Prototype & Product Development
- ❑ Assembly
- ❑ Testing

Weldex

- ❑ Specialist Welding
- ❑ High integrity Fabrication
- ❑ Reclamation Welding
- ❑ Site Projects
- ❑ ISO 3834

Streamline

- ❑ Waterjet Cutting
- ❑ Laser Cutting
- ❑ Finishing Services